



General-Purpose Vibration Meter
VM-83

For Measurement of Acceleration, Velocity, Displacement

Measure and Evaluate Vibrations Detected with

General-Purpose Vibration Meter

VM-83

Four types of inputs and support for acceleration, velocity, and displacement measurements

► Features

- Connectivity for various kinds of accelerometers enables a wide range of vibration measurements
- Comparator function with level evaluation output
- Versatile display characteristics including rms, equivalent peak, equivalent peak-to-peak, maximum value hold, and peak hold
- AC and DC output connectors
- Serial interface for enhanced connectivity
- Data printout capability via serial interface
- VM-83 management software VM-83PB1 (Optional accessories)

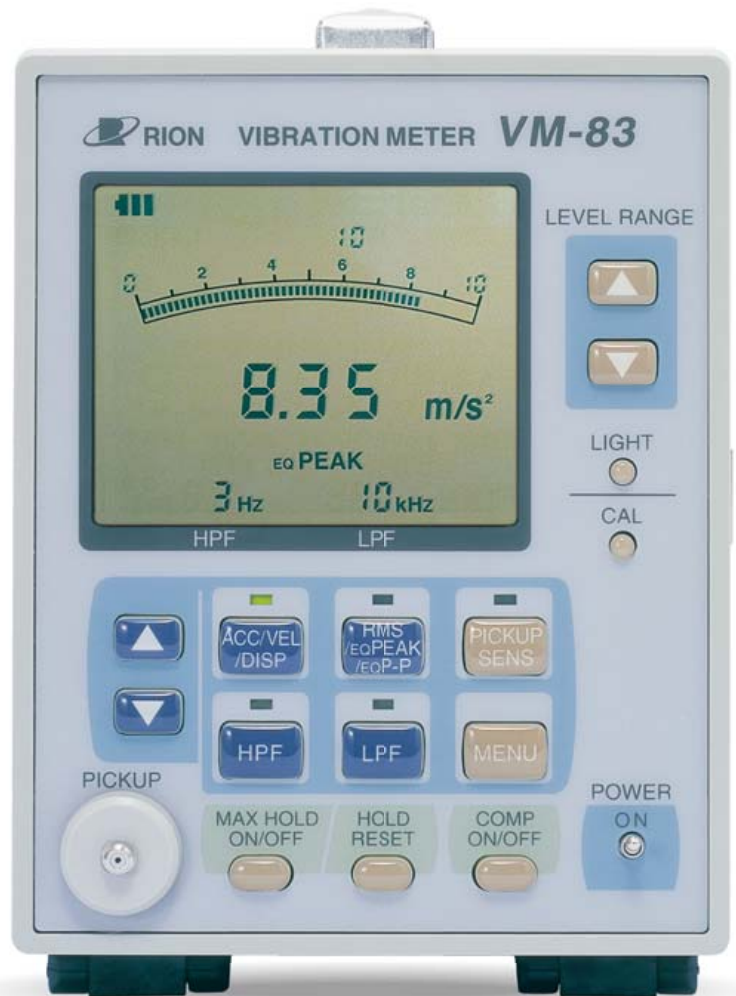

VM-83 Connection Examples

Input side

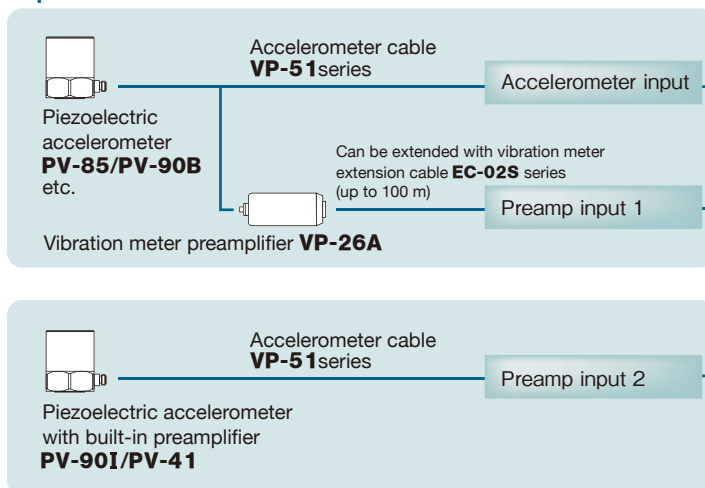

Output side

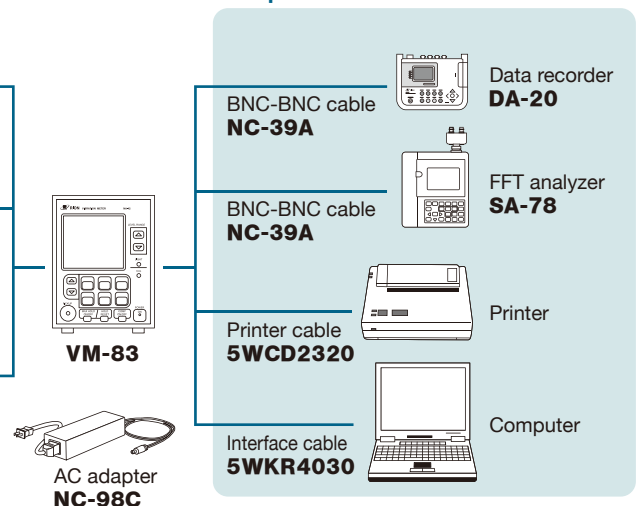

Piezoelectric Accelerometer



Application Examples

Product testing

Vibration meter allows detection of problems related to vibration phenomena. When vibrations above a certain threshold level continue for more than a preset time, an alarm signal is output by the built-in comparator. This allows automatic evaluation.

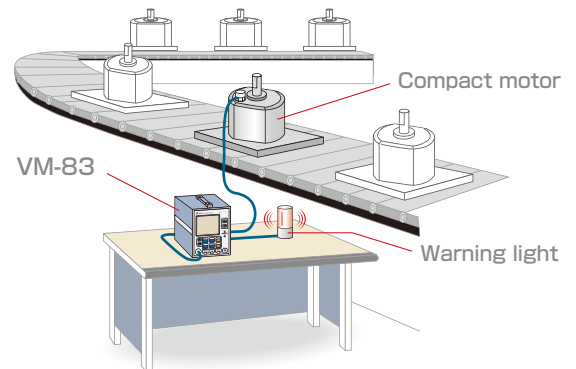

Equipment diagnosis

Detect various problem conditions of manufacturing equipment, ranging from low-frequency vibrations caused by unbalance or misalignment to high-frequency problems caused by bearing vibrations. The comparator function can be used for pass/fail evaluation based on vibration values.

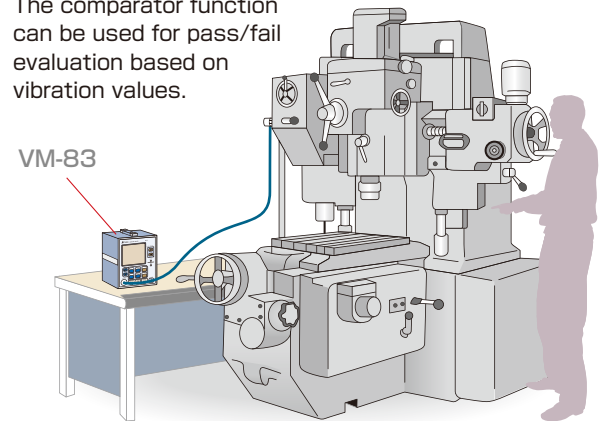

Discontinued
VM-83 management software

VM-83PB1

(OS:Microsoft Windows98/98SE/ME/2000/XP)

VM-83PB1 is a software package which allows controlling settings and measurement operation of the VM-83 from a computer. Measurement data downloaded from the VM-83 can be displayed on the computer and converted to CSV format for further processing and storage. The program also allows control over cutoff frequencies of filters in the VM-83 (user filter function).



Main menu screen



Measurement screen example

Specifications

Input Section	
Accelerometer input	For piezoelectric accelerometers Maximum input charge 30 000 pC
Preamplifier input 1	For connection of piezoelectric accelerometers via preamplifier VP-26A
Preamplifier input 2	For connection of piezoelectric accelerometers with integrated preamplifier; voltage and current supply: 18 V, 2 mA
Measurement modes	
Acceleration (ACC)	m/s ²
Velocity (VEL)	mm/s
Displacement (DISP)	mm
Measurement range	
Piezoelectric	Accelerometer sensitivity 1.00 to 9.99 pC/ (m/s ²)
Acceleration	0.3, 1, 3, 10, 30, 100, 300, 1 000
Velocity	3, 10, 30, 100, 300, 1 000
Displacement	1, 3, 10, 30, 100, 300, 1 000 (HPF 1 Hz)
Displacement	0.3, 1, 3, 10, 30, 100, 300, 1 000 (HPF 3 Hz)
Displacement	0.03, 0.1, 0.3, 1, 3, 10, 30, 100 (HPF 10 Hz or higher)
	For accelerometer sensitivity 0.030 to 0.999 pC/ (m/s ²), multiply above figures by 10
	For accelerometer sensitivity 10.0 to 99.9 pC/ (m/s ²), multiply above figures by 1/10
Vibration frequency range	
Piezoelectric	
Acceleration	1 Hz to 20 kHz ± 5 %
Velocity	1 Hz to 3 Hz ± 10 %, 3 Hz to 3 kHz ± 5 %
Displacement	1 Hz to 3 Hz ± 20 %, 3 Hz to 500 Hz ± 10 %
Filters	
Piezoelectric	
High-pass filter (HPF)	1, 3, 10, 20, 50 Hz (-10 % point, 3rd-order)
Low-pass filter (LPF)	100, 300, 1 k, 3 k, 10 kHz (-10 % point, 3rd-order)
Display characteristics	
RMS	True RMS
Equivalent peak (EQ PEAK)	RMS × √2
Equivalent peak-to-peak (EQ P-P)	RMS peak × 2
Maximum value hold	Holds maximum value in selected mode at selected display characteristics
Peak hold	Holds peak of acceleration waveform
Comparator function	
Comparator level setting	Based on level evaluation
Comparator level setting	In steps of 2 % of full-scale range
Delay time setting	0 to 9 s in 1-s steps
Auto reset time	0 to 90 s in 1-s steps, ON, OFF
Comparator output	Open-collector output (maximum applied voltage 24 V, maximum drive current 25 mA) Buzzer output (on/off selectable), LCD flashing
LCD functions	
Bar graph	Linear scale, value sampled every 100 ms
Measurement value	4-digit numeric display (average of 20 instantaneous value samples taken at 100 ms intervals, display updated every 2 seconds)
Measurement mode	Display characteristics, filter, battery capacity (3-stage indication)
Calibration	
Accelerometer sensitivity	0.030 to 0.999 pC/ (m/s ²), 1.00 to 9.99 pC/ (m/s ²), 10.0 to 99.9 pC/ (m/s ²)
Calibration output	Signal for external equipment calibration
AC	
Piezoelectric	80 Hz ± 2 %, 2 V ± 2 %
DC	2 V ± 2 %

Outputs						
AC output	Range full-scale 2 V, output impedance 600 Ω, BNC connector					
Output voltage accuracy						
Piezoelectric (unit electrical characteristics, 80 Hz)						
Acceleration	Range full-scale ± 2 %					
Velocity	Range full-scale ± 3 %					
Displacement	Range full-scale ± 5 %					
DC output	Range full-scale 2 V, output impedance 600 Ω, BNC connector					
Output voltage accuracy						
Piezoelectric (unit electrical characteristics, 80 Hz)						
Acceleration	Range full-scale ± 2 %					
Velocity	Range full-scale ± 3 %					
Displacement	Range full-scale ± 5 %					
Noise level (typical)						
Noise level with accelerometer input, sensitivity 5.00 pC/ (m/s ²)						
Measurement range	Measurement mode	HPF	LPF	Display	Noise level	
Acceleration	0.3	OFF	OFF	RMS	0.004 m/s ²	
Velocity	3	1 Hz	OFF	RMS	0.1 mm/s	
Displacement	1	1 Hz	OFF	RMS	0.015 mm	
Displacement	0.03	10 Hz	OFF	RMS	0.0003 mm	
Noise level (example) with piezoelectric accelerometer connected						
Accelerometer type	Measurement mode	Measurement range	HPF	LPF	Display	Noise level
PV-85	Acceleration	0.3	OFF	OFF	RMS	0.0034 m/s ²
	Velocity	3	10 Hz	OFF	RMS	0.004 mm/s
	Displacement	0.03	10 Hz	OFF	RMS	0.0002 mm
PV-90B	Acceleration	3	OFF	OFF	RMS	0.133 m/s ²
	Velocity	30	10 Hz	OFF	RMS	0.17 mm/s
	Displacement	0.3	10 Hz	OFF	RMS	0.007 mm
Interface						
Serial interface	For data output and remote control of VM-83					
Printer output	For printing of measurement data (on CP-10, CP-11, DPU-414)					
Power requirements						
Current consumption	IEC R14 (size D) batteries × 4, or AC adapter (NC-98C, option)					
Continuous operation on batteries	Approx. 190 mA (varies depending on measurement conditions)					
Ambient conditions for use	Approx. 20 hours using alkaline batteries					
Dimensions and weight	-10 to 50 °C, 20 to 90 % RH (no condensation)					
Supplied accessories	171 (H) × 120 (W) × 234 (D) mm, approx. 1.8 kg					
	Storage case × 1					
	IEC R14 (size D) batteries × 4 (manganese)					

Optional accessories

Name	Model
VM-83 management software	VM-83PB1 (Discontinued)
AC adapter	NC-98C
Piezoelectric accelerometer	Various
Vibration meter preamplifier	VP-26A
Vibration meter extension cable	EC-02S series (3 m and up)
Printer cable	5WCD2320
Interface cable	5WKR4030
Printer	DPU-414



RION Co., Ltd. is recognized by the JCSS which uses ISO/IEC 17025 (JIS Q 17025) as an accreditation standard and bases its accreditation scheme on ISO/IEC 17011. JCSS is operated by the accreditation body (IA Japan) which is a signatory to the Asia Pacific Laboratory Accreditation Cooperation (APLAC) as well as the International Laboratory Accreditation Cooperation (ILAC). The Quality & Environmental Management system Center of RION Co., Ltd. is an international MRA compliant JCSS operator with the accreditation number JCSS 0197.

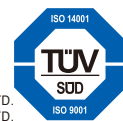

ISO 14001 RION CO., LTD.
ISO 9001 RION CO., LTD.

* Windows is a trademark of Microsoft Corporation. * Specifications subject to change without notice.

Distributed by:

 **RION CO., LTD.**
http://rion-sv.com/

3-20-41, Higashimotomachi, Kokubunji, Tokyo 185-8533, Japan
Tel: +81-42-359-7888 Fax: +81-42-359-7442

This leaflet is printed with environmentally friendly UV ink on recycled paper.