

DIGITAL THICKNESS GAGES

DATA
OUTPUT

measuring tips
and anvils can be
custom-made

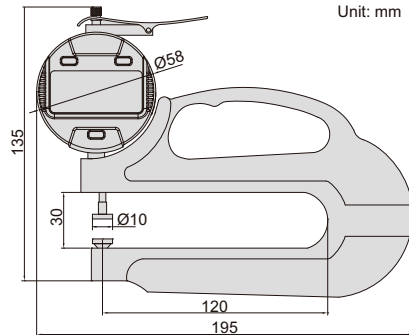

Unit: mm



2872-10

- Ceramic spindle tip and anvil
- Buttons: on/off, inch/mm, zero, data preset, change measuring direction, absolute/incremental measurement
- Keep preset data in memory after restart
- Battery CR2032, automatic power off
- Data output
- Optional accessory: data output cable (code **7315-50M**, **7302-50M**)

Code	Range	Resolution	Accuracy
2872-10	0-10mm/0-0.4"	0.01mm/0.0005"	±0.02mm
2872-101	0-10mm/0-0.4"	0.001mm/0.00005"	±0.01mm